

1. Assistant Pharmacist

■ Level of Position

- ❖ Entry Level

■ Duties and Responsibilities

- ❖ Assist to the pharmacist when issuing drugs
- ❖ Assist to Drug dispatch
- ❖ Clean pharmacy equipment, help with the maintenance of equipment and supplies
- ❖ Manage the cash register and handling money transactions
- ❖ Use store's computer systems to generate label and stock lists
- ❖ Help in maintaining reasonable dispensary stock levels

■ Salary Scale (Rs.)

- ❖ Maximum- Rs.30,000/=
- ❖ Minimum - Rs.20,000/=

■ Working Hours

- ❖ 08 hours

■ Age Limit (Years)

- ❖ Upper Limit -55
- ❖ Lower Limit - 18

■ Gender Preference

- ❖ Both Gender

■ Required Educational Qualifications

- ❖ GCE O/L & GCE A/L

■ Diploma & Certificate Qualifications

- ❖ Certificate in Pharmacy

■ Preferred Institute

- ❖ Sri Lanka Medical Council
- ❖ Pharmaceutical Society in Sri Lanka
- ❖ Any recognized institute in Sri Lanka (Aquinas College/PATE Academy)

■ Language Skills

Language	Expected Level
Sinhala	High
English	Moderate
Tamil	Fair

■ Soft Skills & Abilities

Kindness	Being Responsible
Team Work	Being Accuracy
Being Organized	Good Communication
Customer Oriented	Strong Key board Skill

■ Required Experience

- ❖ Not Specified

■ Career Pathway

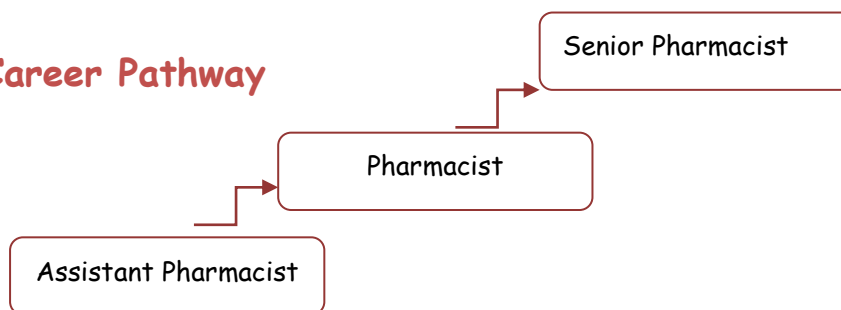

2. Pharmacist

■ Level of Position

- ❖ Middle Level

■ Duties and Responsibilities

- ❖ Issuing correct medicines for the correct perceptions
- ❖ Checking dosage and ensuring that medicines are correctly and safely supplied and labeled
- ❖ Drugs Dispatching, Drugs preparing
- ❖ Keeping a register of controlled drugs for legal and stock control purposes;
- ❖ Advising patients of any adverse side-effects of medicines or potential interactions with other medicines/treatments

■ Salary Scale (Rs.)

- ❖ Maximum- Rs.35,000/=
- ❖ Minimum - Rs.20,000/=

■ Working Hours

- ❖ 08 hours

■ Age Limit (Years)

- ❖ Upper Limit -55
- ❖ Lower Limit - 18

■ Gender Preference

- ❖ Both Gender

■ Required Educational Qualifications

- ❖ GCE O/L
- ❖ GCE A/L- Biology/Mathematics

■ Diploma & Certificate Qualifications

- ❖ Higher Diploma in Pharmacist

■ Preferred Institute

- ❖ Sri Lanka Medical Council
- ❖ Pharmaceutical Society in Sri Lanka
- ❖ Any recognized institute in Sri Lanka (Aquinass College/PATE Academy)

■ Language Skills

Language	Expected Level
Sinhala	High
English	Moderate
Tamil	Fair

■ Soft Skills & Abilities

Kindness	Being Responsible
Team Work	Being Accuracy & Meticulous
Being Organized	Good Communication
Customer Oriented	Ability to work with others in a multidisciplinary team

■ Required Experience

- ❖ Two Years Experience in Pharmacist

■ Career Pathway

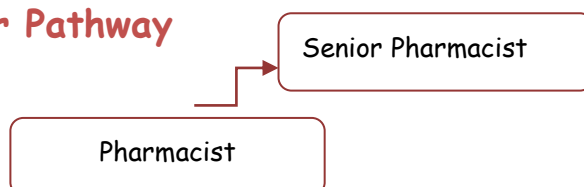

3. Bio-Medical Manager

■ Level of Position

- ❖ Mid Level

■ Duties and Responsibilities

- ❖ Undertaking physiological Principles and the safe clinical application of biomedical equipment
- ❖ Equipment Inspections, Corrective Maintenance, Calibrations, Equipment Installations

■ Salary Scale (Rs.)

- ❖ Maximum- Rs.30,000/=
- ❖ Minimum - Rs.20,000/=

■ Working Hours

- ❖ 08 hours

■ Age Limit (Years)

- ❖ Upper Limit -55
- ❖ Lower Limit - 18

■ Gender Preference

- ❖ Male Preferred

■ Required Educational Qualifications

- ❖ GCE O/L
- ❖ GCE A/L-Biology
- ❖ Degree in Biomedical

■ Diploma & Certificate Qualifications

- ❖ Diploma in Bio Medical Science

■ Preferred Institute

- ❖ Sri Lanka Management and Science Institute
- ❖ Any recognition institute in Sri Lanka

■ Language Skills

Language	Expected Level
Sinhala	High
English	Moderate
Tamil	Fair

■ Soft Skills

Communication	Quality Control Analysis
Problem Solving	Time Management
Team Work	System Analysis
Efficiency	Critical Thinking

■ Required Experience

- ❖ Five Years Experience in Bio-Medical

■ Career Pathway

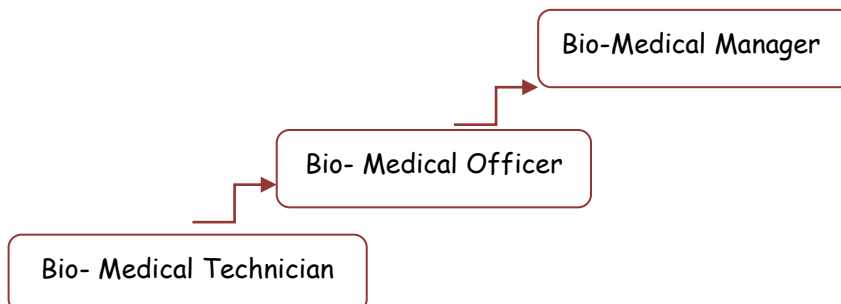

4. ECG Technician

■ Level of Position

- ❖ Middle Level

■ Duties and Responsibilities

- ❖ Record the ECG of patients referred by medical officer
- ❖ Upkeep of all type of E.C.G. Machines and other electronic gadgets
- ❖ Provide technical support to assist doctors in any emergency situation
- ❖ Undertake some minor repairing and calibrating work of cardiac equipments

■ Salary Scale (Rs.)

- ❖ Maximum- Rs.30000/=
- ❖ Minimum - Rs. 25000/=

■ Working Hours

- ❖ 08 hours

■ Age Limit (Years)

- ❖ Upper Limit -55
- ❖ Lower Limit - 18

■ Gender Preference

- ❖ Both Gender

■ Required Educational Qualifications

- ❖ GCE O/L
- ❖ GCE A/L-Biology

■ Diploma & Certificate Qualifications

Diploma in ECG Technician

■ Preferred Institute

❖ Any Recognized Institute in Sri Lanka

■ Language Skills

Language	Expected Level
Sinhala	High
English	Moderate
Tamil	Fair

■ Soft Skills

Communication	Manual dexterity
Problem Solving	Situational awareness
Efficiency	Physical endurance
Attention to detail	Computer competency

■ Required Experience

❖ One Year Experience in Nursing

■ Career Pathway

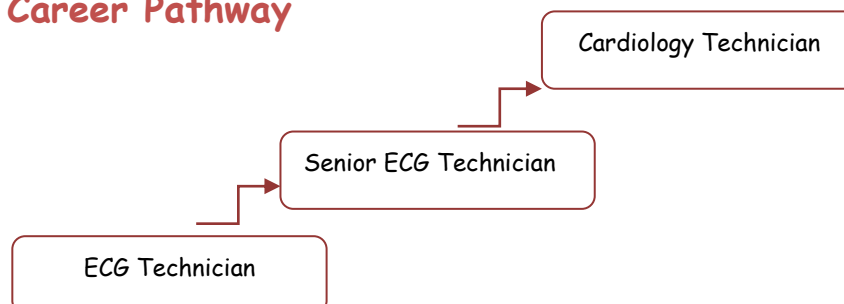

5. Physiotherapist

■ Level of Position

- ❖ High Level

■ Duties and Responsibilities

- ❖ To ensure a high standard of clinical care to inpatient and hydrotherapy patients under your management
- ❖ To undertake comprehensive assessments of patients and to formulate effective, clinically reasoned treatment plans
- ❖ To carry out timely assessment and treatment of a mixed caseload of inpatients and to facilitate safe discharge home from the hospital
- ❖ To be competent in using a wide variety of assessment techniques and skills
- ❖ To assess patients' needs for any rehabilitative equipment and aids to improve safety and functioning within the home

■ Salary Scale (Rs.)

- ❖ Maximum- Rs.25,000/=
- ❖ Minimum - Rs.20,000/=

■ Working Hours

- ❖ 08 hours

■ Age Limit (Years)

- ❖ Upper Limit -55
- ❖ Lower Limit - 18

■ Gender Preference

- ❖ Both Gender

■ Required Educational Qualifications

- ❖ GCE O/L
- ❖ GCE A/L- Biology, IT
- ❖ Degree-Physiotherapist

■ Diploma & Certificate Qualifications

- ❖ Higher Diploma in Physiotherapist

■ Preferred Institute

- ❖ Any recognized institute in Sri Lanka

■ Language Skills

Language	Expected Level
Sinhala	High
English	Moderate
Tamil	Fair

■ Soft Skills

Communication	Kindness
Problem Solving	Being Smart

■ Required Experience

- ❖ Two Years experience in Physiotherapy

■ Career Pathway

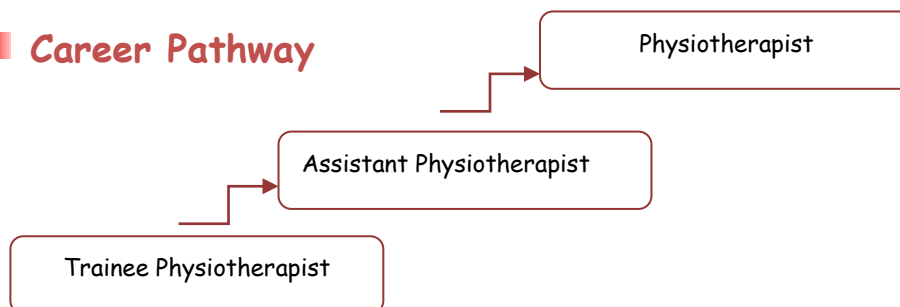

6. Radiographer

■ Level of Position

- ❖ High Level

■ Duties and Responsibilities

- ❖ Assessing patients and their clinical requirements to determine appropriate radiographic techniques
- ❖ performing a range of radiographic examinations on patients to produce high-quality images
- ❖ observing and maintaining contact with patients during their waiting, examination and post-examination stay in the department
- ❖ assisting in more complex radiological examinations working with radiologists and doctors and surgeons

■ Salary Scale (Rs.)

- ❖ Maximum- Rs.30,000/=
- ❖ Minimum - Rs.25,000/=

■ Working Hours

- ❖ 08 hours

■ Age Limit (Years)

- ❖ Upper Limit -55
- ❖ Lower Limit - 18

■ Gender Preference

- ❖ Both Gender

■ Required Educational Qualifications

- ❖ GCE O/L & GCE A/L
- ❖ Degree- Biology

■ Diploma & Certificate Qualifications

- ❖ Diploma in Radiographer

■ Preferred Institute

- ❖ Sri Lanka School of Radiography
- ❖ Any recognized institute in Sri Lanka

■ Language Skills

Language	Expected Level
Sinhala	High
English	Moderate
Tamil	Fair

■ Soft Skills

Communication	Efficiency
Kindness	Team Work
Being Flexibility	Self Confidence

■ Required Experience

- ❖ One Year in Radiographer

■ Career Pathway

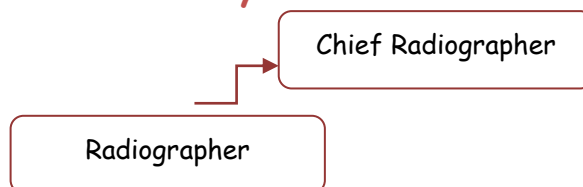

7. Medical Officer

■ Level of Position

- ❖ High Level

■ Duties and Responsibilities

- ❖ To take care of the ward patients
- ❖ Explain their conditions and services

■ Salary Scale (Rs.)

- ❖ Maximum- Rs.70,000/=
- ❖ Minimum - Rs.50,000/=

■ Working Hours

- ❖ 06 hours

■ Age Limit (Years)

- ❖ Upper Limit -55
- ❖ Lower Limit - 30

■ Gender Preference

- ❖ Both Gender

■ Required Educational Qualifications

- ❖ Degree-MBBS

■ Diploma & Certificate Qualifications

- ❖

■ Preferred Institute



■ Language Skills

Language	Expected Level
Sinhala	High
English	High
Tamil	Fair

■ Soft Skills

- ❖ Kindness
- ❖ Team Work

■ Required Experience

- ❖ Not Specified

■ Career Pathway

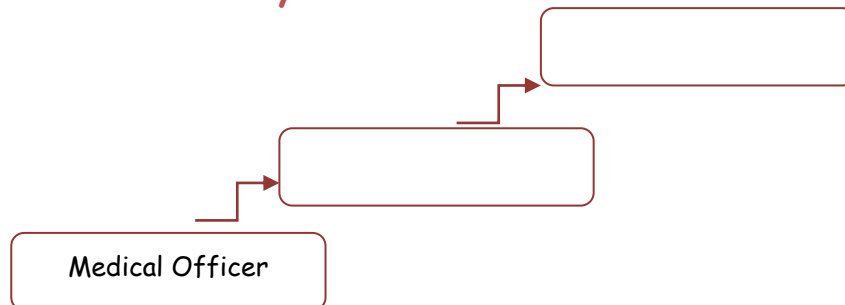

8. Junior Nurse

■ Level of Position

- ❖ Entry Level

■ Duties and Responsibilities

- ❖ Preparing rooms, and decontaminating equipments and instruments.
- ❖ Preparing patients for examinations
- ❖ Assisting Senior nurse in patient caring

■ Salary Scale (Rs.)

- ❖ Maximum- Rs.30,000/=
- ❖ Minimum - Rs.20,000/=

■ Working Hours

- ❖ 06 hours

■ Age Limit (Years)

- ❖ Upper Limit -55
- ❖ Lower Limit - 18

■ Gender Preference

- ❖ Both Gender

■ Required Educational Qualifications

- ❖ GCE O/L
- ❖ GCE A/L - Bio Science

■ Diploma & Certificate Qualifications

- ❖ Diploma in Nursing

■ Preferred Institute

❖ SAITM

■ Language Skills

Language	Expected Level
Sinhala	High
English	Moderate
Tamil	Fair

■ Soft Skills

Communication	Efficiency
Kindness	Team Work
Being Flexibility	Self Confidence

■ Required Experience

❖ Not Specified

■ Career Pathway

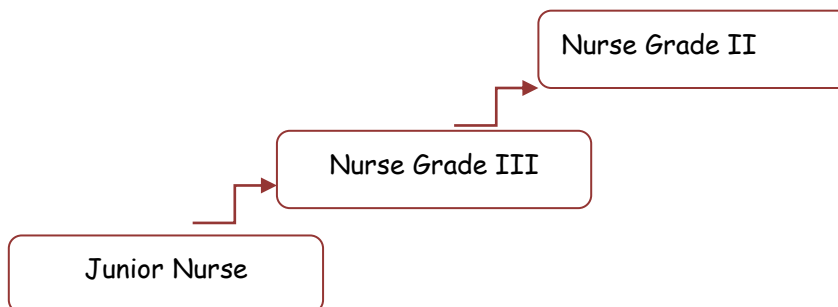

9. Nurse

■ Level of Position

- ❖ High Level

■ Duties and Responsibilities

- ❖ Patient care and observing and recording patients' behavior
- ❖ Maintaining reports of patients' medical histories, and monitoring changes in their condition
- ❖ Carrying out the requisite treatments and medications
- ❖ Drug administration and handling the medical equipment

■ Salary Scale (Rs.)

- ❖ Maximum- Rs.50,000/=
- ❖ Minimum - Rs.46,000/=

■ Working Hours

- ❖ 06 hours

■ Age Limit (Years)

- ❖ Upper Limit -55
- ❖ Lower Limit - 18

■ Gender Preference

- ❖ Both Gender

■ Required Educational Qualifications

- ❖ GCE O/L
- ❖ GCE A/L- Bio Science

■ Diploma & Certificate Qualifications

- ❖ Diploma in Nursing

■ Preferred Institute

- ❖ NTS

■ Language Skills

Language	Expected Level
Sinhala	High
English	High
Tamil	Fair

■ Soft Skills

Communication	Efficiency
Kindness	Team Work
Being Flexibility	Self Confidence

■ Required Experience

- ❖ Two Years Experience in Nursing

■ Career Pathway

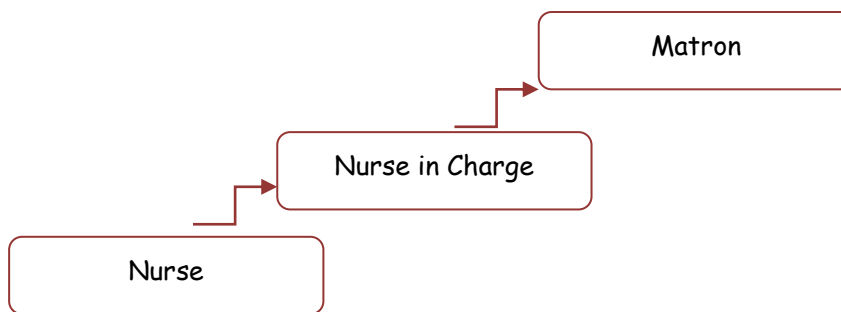

10. Nurse in Charge

■ Level of Position

- ❖ High Level

■ Duties and Responsibilities

- ❖ Unit admin and Management & Duty Roster Management
- ❖ Allocate staff for the assist consultation
- ❖ Allocate staff for the procedures
- ❖ On the job train staff for the unit requirement
- ❖ Take consultants patient feedback

■ Salary Scale (Rs.)

- ❖ Maximum- Rs.70,000/=
- ❖ Minimum - Rs.50,000/=

■ Working Hours

- ❖ 08 hours

■ Age Limit (Years)

- ❖ Upper Limit -55
- ❖ Lower Limit - 30

■ Gender Preference

- ❖ Both Gender

■ Required Educational Qualifications

- ❖ GCE O/L
- ❖ GCE A/L-Bio Science

■ Diploma & Certificate Qualifications

- ❖ Diploma in Nursing

■ Preferred Institute

- ❖ Nurses Training School (NTS)
- ❖ Any recognized institute in Sri Lanka

■ Language Skills

Language	Expected Level
Sinhala	High
English	High
Tamil	Fair

■ Soft Skills

Communication	Efficiency
Kindness	Team Work
Leadership	Problem Solving

■ Required Experience

- ❖ Three Years Experience in Nursing

■ Career Pathway

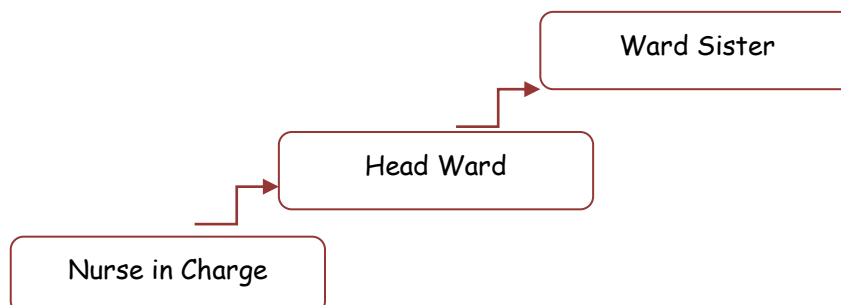

11. Staff Nurse

■ Level of Position

- ❖ Middle Level

■ Duties and Responsibilities

- ❖ Nursing Care
- ❖ Home Care Service
- ❖ Check the inventory

■ Salary Scale (Rs.)

- ❖ Maximum- Rs.40,000/=
- ❖ Minimum - Rs.20,000/=

■ Working Hours

- ❖ 06 hours

■ Age Limit (Years)

- ❖ Upper Limit -55
- ❖ Lower Limit - 18

■ Gender Preference

- ❖ Both Gender

■ Required Educational Qualifications

- ❖ GCE O/L
- ❖ GCE A/L-Bio Science

■ Diploma & Certificate Qualifications

- ❖ Diploma in Nursing

■ Preferred Institute

- ❖ NTS
- ❖ Any recognized institute in Sri Lanka

■ Language Skills

Language	Expected Level
Sinhala	High
English	Moderate
Tamil	Fair

■ Soft Skills

Communication	Efficiency
Kindness	Team Work
Leadership	Problem Solving

■ Required Experience

- ❖ Not Specified

■ Career Pathway

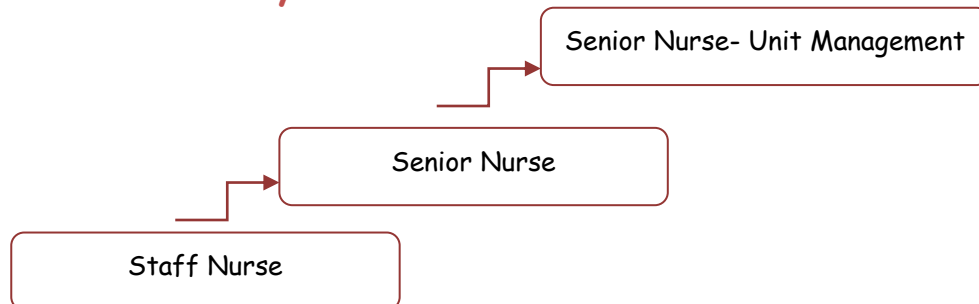

12. Nurse Aid

■ Level of Position

- ❖ Entry Level

■ Duties and Responsibilities

- ❖ Assist to patients care
- ❖ Provide patients personal Hygiene
- ❖ Help to setting up medical equipments

■ Salary Scale (Rs.)

- ❖ Maximum- Rs.25,000/=
- ❖ Minimum - Rs.20,000/=

■ Working Hours

- ❖ 08 hours

■ Age Limit (Years)

- ❖ Upper Limit -55
- ❖ Lower Limit - 18

■ Gender Preference

- ❖ Both Gender

■ Required Educational Qualifications

- ❖ GCE O/L & GCE A/L

■ Diploma & Certificate Qualifications

- ❖ Certificate in first aid and nursing care

■ Preferred Institute

- ❖ SMI Training Institute
- ❖ Any recognition institute in Sri Lanka

■ Language Skills

Language	Expected Level
Sinhala	High
English	Fair
Tamil	Fair

■ Soft Skills

Communication	Time Management
Kindness	Multitasking Skill
Team Work	Self Confidence

■ Required Experience

- ❖ Not Specified

■ Career Pathway

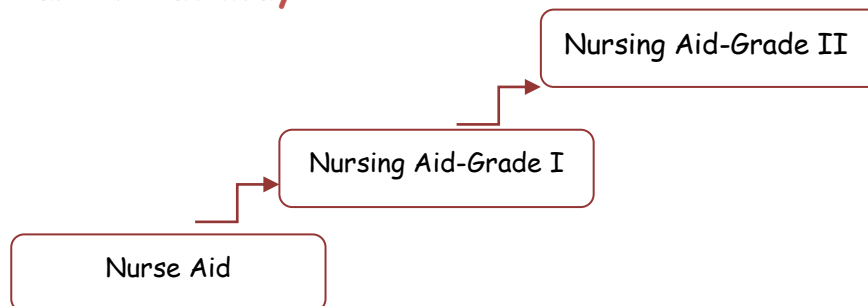

13. Ward Assistant

■ Level of Position

- ❖ Middle Level

■ Duties and Responsibilities

- ❖ Lift patients on and off beds, with the assistance of nurses
- ❖ Transfer patient s' files and x-rays between department s, specimens to laboratories
- ❖ Make sure that an adequate supply of clean clothing and linen is available for the patient and that soiled items are removed and cleaned
- ❖ Help to the ward clerk and assist in administrative duties such as photocopying ward forms

■ Salary Scale (Rs.)

- ❖ Maximum- Rs.25,000/=
- ❖ Minimum - Rs.20,000/=

■ Working Hours

- ❖ 08 hours

■ Age Limit (Years)

- ❖ Upper Limit -55
- ❖ Lower Limit - 18

■ Gender Preference

- ❖ Both Gender

■ Required Educational Qualifications

- ❖ GCE O/L & GCE A/L

■ Diploma & Certificate Qualifications

- ❖ Not Specified

■ Preferred Institute

- ❖ Not Specified

■ Language Skills

Language	Expected Level
Sinhala	High
English	Moderate
Tamil	Fair

■ Soft Skills

Communication	Time Management
Kindness	Multitasking Skill
Team Work	Self Confidence

■ Required Experience

- ❖ Not Specified

■ Career Pathway

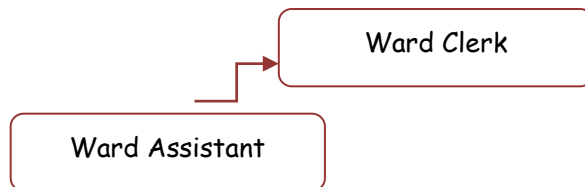

14. Ward Clerk

■ Level of Position

- ❖ Middle Level

■ Duties and Responsibilities

- ❖ Maintain the patient
- ❖ Coordinate with department
- ❖ Provide assistance to nurses & guide patient

■ Salary Scale (Rs.)

- ❖ Maximum- Rs.30,000/=
- ❖ Minimum - Rs.20,000/=

■ Working Hours

- ❖ 08 hours

■ Age Limit (Years)

- ❖ Upper Limit -55
- ❖ Lower Limit - 18

■ Gender Preference

- ❖ Both Gender

■ Required Educational Qualifications

- ❖ GCE O/L & GCE A/L

■ Diploma & Certificate Qualifications

- ❖ Not Specified

Preferred Institute

❖ Not Specified

■ Language Skills

Language	Expected Level
Sinhala	High
English	Moderate
Tamil	Fair

■ Soft Skills

Communication	Time Management
Kindness	Multitasking Skill
Team Work	Self Confidence

■ Required Experience

❖ One Year Experience in Ward Clerk

■ Career Pathway

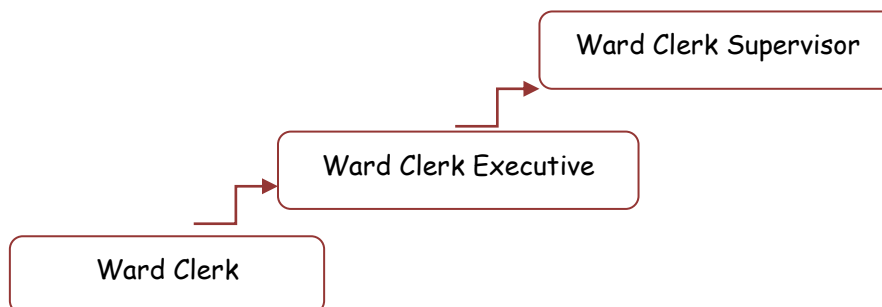

15. Ward Master

■ Level of Position

- ❖ High Level

■ Duties and Responsibilities

- ❖ Supervisory level (total nursing care)
- ❖ Daily check- inventories
- ❖ Home care nursing service
- ❖ Health education
- ❖ Take care of patient, total nursing care

■ Salary Scale (Rs.)

- ❖ Maximum- Rs.45,000/=
- ❖ Minimum - Rs.40,000/=

■ Working Hours

- ❖ 08 hours

■ Age Limit (Years)

- ❖ Upper Limit -55
- ❖ Lower Limit - 18

■ Gender Preference

- ❖ Both Gender

■ Required Educational Qualifications

- ❖ GCE O/L
- ❖ GCE A/L-Biology

■ Diploma & Certificate Qualifications

- ❖ Diploma in General Nursing

■ Preferred Institute

- ❖ Any recognized institute in Sri Lanka

■ Language Skills

Language	Expected Level
Sinhala	High
English	Moderate
Tamil	Fair

■ Soft Skills

Communication	Time Management
Kindness	Multitasking Skill
Team Work	Self Confidence

■ Required Experience

- ❖ Not Specified

■ Career Pathway

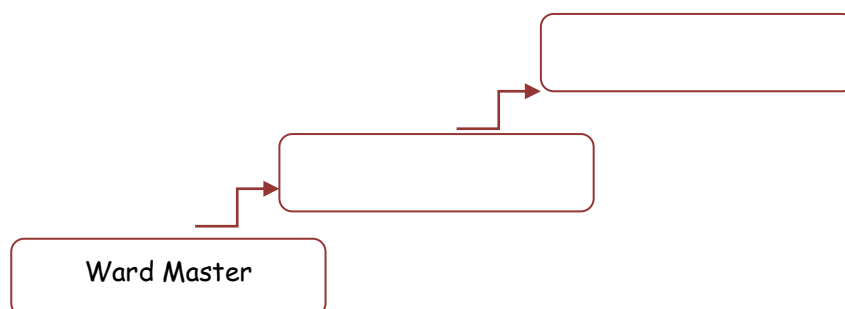

16. Lab Technician

■ Level of Position

- ❖ Middle Level

■ Duties and Responsibilities

- ❖ Prepare tissue for microscopic examination by pathologists
- ❖ Daily instrument maintenance and quality control
- ❖ Sample testing
- ❖ Collection and interpretation of data
- ❖ Maintenance of accurate records and reporting of data
- ❖ Actively participates in Quality Improvement Programs essential to ensure that laboratory testing is accurate, timely and meets customer needs

■ Salary Scale (Rs.)

- ❖ Maximum- Rs.35000/=
- ❖ Minimum - Rs.20000/=

■ Working Hours

- ❖ 8 Hours

■ Age Limit (Years)

- ❖ Upper Limit -55
- ❖ Lower Limit - 18

■ Gender Preference

- ❖ Both Gender

■ Required Educational Qualifications

- ❖ GCE O/L
- ❖ GCE A/L-Biology

■ Diploma & Certificate Qualifications

- ❖ Certificate Programme in Laboratory Technology
- ❖ Higher National Diploma (HND) in Medical Laboratory Technology

■ Preferred Institute

- ❖ The School of Medical Laboratory Technology (MLT)
- ❖ Open University in Sri Lanka
- ❖ PATHE Academy

■ Language Skills

Language	Expected Level
Sinhala	High
English	Moderate
Tamil	Fair

■ Soft Skills

Communication	Time Management
Interpersonal Skills	Multitasking Skill
Team Work	Self Confidence

■ Required Experience

- ❖ Not Specified

■ Career Pathway

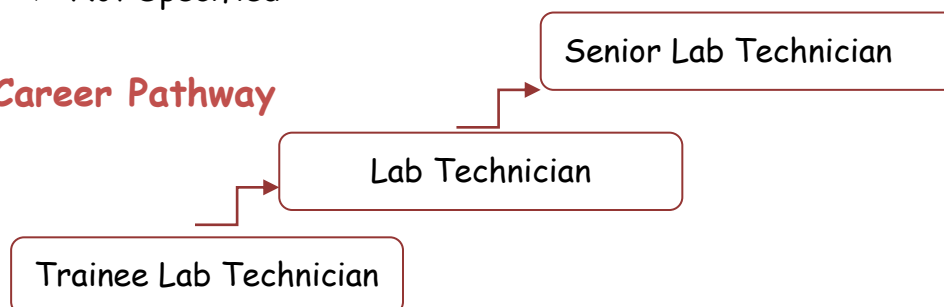

17. X-Ray Technician

■ Level of Position

- ❖ Middle Level

■ Duties and Responsibilities

- ❖ Responsible for operating the medical equipment used to capture internal images of patients' bodies
- ❖ Precisely follow orders from physicians on what areas of the body to image
- ❖ Prepare patients for procedures, including taking a medical history and answering questions about the procedure
- ❖ Operate the computerized equipment to take the images
- ❖ Work with physicians to evaluate the images and to determine whether additional images need to be taken
- ❖ Keep detailed patient records

■ Salary Scale (Rs.)

- ❖ Maximum- Rs.30000/=
- ❖ Minimum - Rs.20000/=

■ Working Hours

- ❖ 8 Hours

■ Age Limit (Years)

- ❖ Upper Limit -55
- ❖ Lower Limit - 18

■ Gender Preference

- ❖ Both Gender

■ Required Educational Qualifications

- ❖ GCE O/L
- ❖ GCE A/L-Biology

■ Diploma & Certificate Qualifications

- ❖ Diploma in Radiography

■ Preferred Institute

- ❖ Sri Lanka College of Radiologists
- ❖ The School of Medical Laboratory Technology (MLT)

■ Language Skills

Language	Expected Level
Sinhala	High
English	Moderate
Tamil	Fair

■ Soft Skills

Communication	Time Management
Interpersonal Skills	Multitasking Skill
Team Work	Self Confidence

■ Required Experience

- ❖ Not Specified

■ Career Pathway

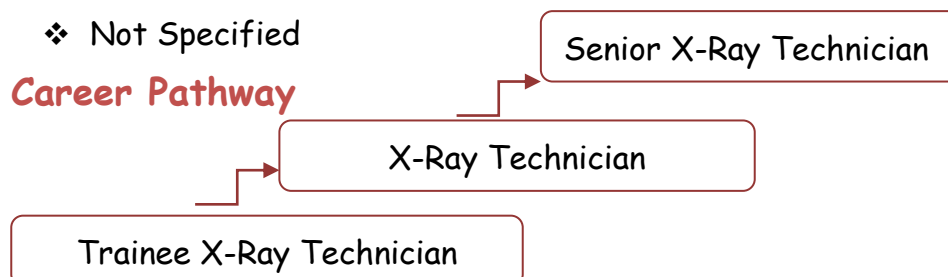

18. Food Inspector

■ Level of Position

- ❖ Middle Level

■ Duties and Responsibilities

- ❖ Monitor food distributors, processors for safety
- ❖ Inspect live animals and carcasses at a slaughterhouse or examine food imports at a port for mislabeling or other food safety issues
- ❖ Report violations to the appropriate regulatory agency and are responsible for ensuring that foods are suitable for human consumption

■ Salary Scale (Rs.)

- ❖ Maximum- Rs. 35000/=
- ❖ Minimum - Rs. 20000/=

■ Working Hours

- ❖ 8 Hours

■ Age Limit (Years)

- ❖ Upper Limit -55
- ❖ Lower Limit - 18

■ Gender Preference

- ❖ Both Gender

■ Required Educational Qualifications

- ❖ GCE O/L
- ❖ GCE A/L-Biology

■ Diploma & Certificate Qualifications

- ❖ Diploma in Food Safety and Quality Management

■ Preferred Institute

- ❖ Any Recognized Institute in Sri Lanka

■ Language Skills

Language	Expected Level
Sinhala	High
English	Moderate
Tamil	Fair

■ Soft Skills

Communication	Time Management
Interpersonal Skills	Multitasking Skill
Team Work	Self Confidence

■ Required Experience

- ❖ Not Specified

■ Career Pathway

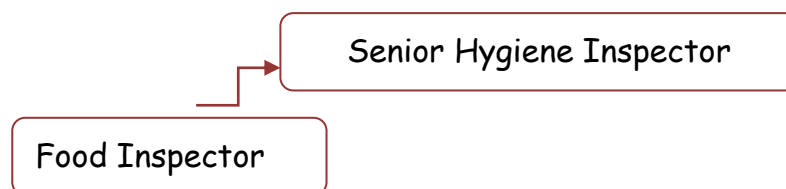

19. Matron

■ Level of Position

- ❖ Middle Level

■ Duties and Responsibilities

- ❖ Securing and assuring higher standards of care by providing leadership to staff
- ❖ Ensuring that administrative and support services are designed and delivered to achieve the highest standards of care
- ❖ Providing a visible, accessible and authoritative presence in ward settings, to whom patients and their families can turn for assistance, advice, and support

■ Salary Scale (Rs.)

- ❖ Maximum- Rs.45000/=
- ❖ Minimum - Rs.35000/=

■ Working Hours

- ❖ 8 Hours

■ Age Limit (Years)

- ❖ Upper Limit -55
- ❖ Lower Limit - 18

■ Gender Preference

- ❖ Both Gender

■ Required Educational Qualifications

- ❖ GCE O/L
- ❖ GCE A/L-Biology

■ Diploma & Certificate Qualifications

- ❖ Diploma in Hospital Administration
- ❖ Diploma in Public Health Management

■ Preferred Institute

- ❖ Any Recognized Institute in Sri Lanka

■ Language Skills

Language	Expected Level
Sinhala	High
English	Moderate
Tamil	Fair

■ Soft Skills

Communication	Time Management
Interpersonal Skills	Multitasking Skill
Team Work	Self Confidence

■ Required Experience

- ❖ Five Years Experience in Warden

■ Career Pathway

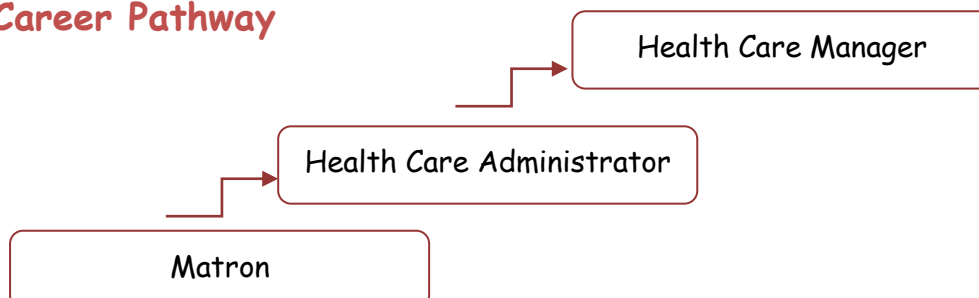

20. Ward Sister

■ Level of Position

- ❖ High Level

■ Duties and Responsibilities

- ❖ Ensure that confidentiality is maintained at all times.
- ❖ Develop good interpersonal relationships with patients, relatives and other members of the multi-disciplinary team.
- ❖ Collaborate with the multi-disciplinary team including community staff to ensure adequate discharge planning and continuity of care
- ❖ Provide advice and support to all staff on clinical matters and give support to junior nurses to help them develop initiative and ensure safe nursing practice on the ward

■ Salary Scale (Rs.)

- ❖ Maximum- Rs.
- ❖ Minimum - Rs.

■ Working Hours

- ❖ 8 Hours

■ Age Limit (Years)

- ❖ Upper Limit -55
- ❖ Lower Limit - 18

■ Gender Preference

- ❖ Both Gender

■ Required Educational Qualifications

- ❖ GCE O/L
- ❖ GCE A/L-Biology

■ Diploma & Certificate Qualifications

- ❖ Diploma in Nursing

■ Preferred Institute

- ❖ Any Recognized Institute in Sri Lanka

■ Language Skills

Language	Expected Level
Sinhala	High
English	Moderate
Tamil	Fair

■ Soft Skills

Communication	Time Management
Interpersonal Skills	Multitasking Skill
Team Work	Self Confidence

■ Required Experience

- ❖ Five Years Experience in Senior Nurse

■ Career Pathway

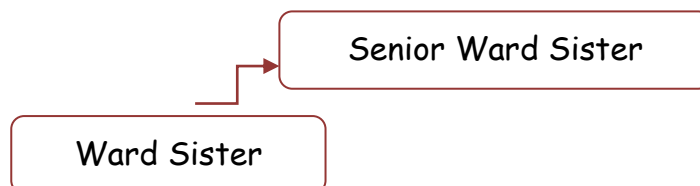

21. Midwife

■ Level of Position

- ❖ Middle Level

■ Duties and Responsibilities

- ❖ Provide sound family planning information and advice
- ❖ To examine and care for the newborn infant: to take all initiatives which are necessary in case of need and to carry out where necessary immediate resuscitation
- ❖ To care for and monitor the progress of the mother in the Postnatal period and to give all necessary advice to the mother on infant care to enable her to ensure the optimum progress of the newborn infant
- ❖ To carry out treatment prescribed by a doctor
- ❖ To maintain all necessary records

■ Salary Scale (Rs.)

- ❖ Maximum- Rs. 40000/=
- ❖ Minimum - Rs. 25000/=

■ Working Hours

- ❖ 9 Hours

■ Age Limit (Years)

- ❖ Upper Limit -55
- ❖ Lower Limit - 18

■ Gender Preference

- ❖ Female Preferred

■ Required Educational Qualifications

- ❖ GCE O/L
- ❖ GCE A/L-Biology

■ Diploma & Certificate Qualifications

- ❖ Not Specified

■ Preferred Institute

- ❖ Not Specified

■ Language Skills

Language	Expected Level
Sinhala	High
English	Moderate
Tamil	Fair

■ Soft Skills

Communication	Kindness
Team Work	Multitasking Skill

■ Required Experience

- ❖ Not Specified

■ Career Pathway

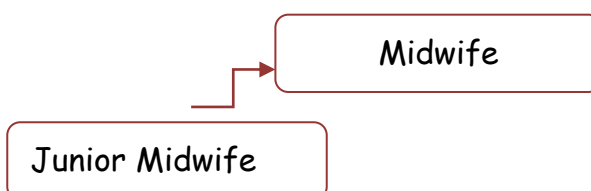

22. Sanitary Supervisor

■ Level of Position

- ❖ Middle Level

■ Duties and Responsibilities

- ❖ Conduct supervision work in relation to sanitary care in the hospital
- ❖ Maintain a record book

■ Salary Scale (Rs.)

- ❖ Maximum- Rs.30000/=
- ❖ Minimum - Rs. 25000/=

■ Working Hours

- ❖ 9 Hours

■ Age Limit (Years)

- ❖ Upper Limit -55
- ❖ Lower Limit - 18

■ Gender Preference

- ❖ Both Gender

■ Required Educational Qualifications

- ❖ GCE O/L
- ❖ GCE A/L

■ Diploma & Certificate Qualifications

❖ Not Specified

■ Preferred Institute

❖ Not Specified

■ Language Skills

Language	Expected Level
Sinhala	High
English	Moderate
Tamil	Fair

■ Soft Skills

Communication	Interpersonal Skill
Team Work	Multitasking Skill

■ Required Experience

❖ Not Specified

■ Career Pathway

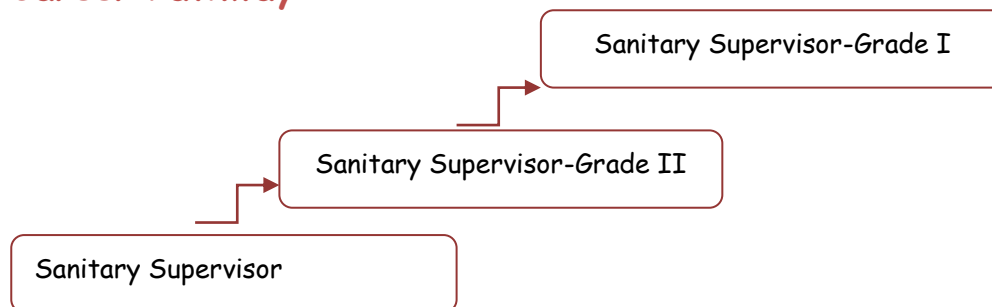

23. Hospital Cleaner

■ Level of Position

- ❖ Entry Level

■ Duties and Responsibilities

- ❖ Undertake general cleaning of all non-clinical areas of the hospital, including offices, floors, corridors, stairwells and toilets
- ❖ Ensure adequate stock levels of cleaning materials are for maintaining and monitoring equipment, tools and stock provided for the job holders use e.g mops, buckets, floor cleaning machine, cleaning fluids etc.
- ❖ Inform the Hospital Manager of stock required for replenishment purposes
- ❖ Undertake routine tasks such as hosing down forecourt & dealing with recycling in the absence of the Hospital Maintenance person
- ❖ Undertake any other duties as requested

■ Salary Scale (Rs.)

- ❖ Maximum- Rs.20000/=
- ❖ Minimum - Rs.15000/=

■ Working Hours

- ❖ 9 Hours

■ Age Limit (Years)

- ❖ Upper Limit -55
- ❖ Lower Limit - 18

■ Gender Preference

- ❖ Both Gender

■ Required Educational Qualifications

- ❖ GCE O/L

■ Diploma & Certificate Qualifications

- ❖ Not Specified

■ Preferred Institute

- ❖ Not Specified

■ Language Skills

Language	Expected Level
Sinhala	High
English	Moderate
Tamil	Fair

■ Soft Skills

Communication	Interpersonal Skill
Team Work	Multitasking Skill

■ Required Experience

- ❖ Not Specified

■ Career Pathway

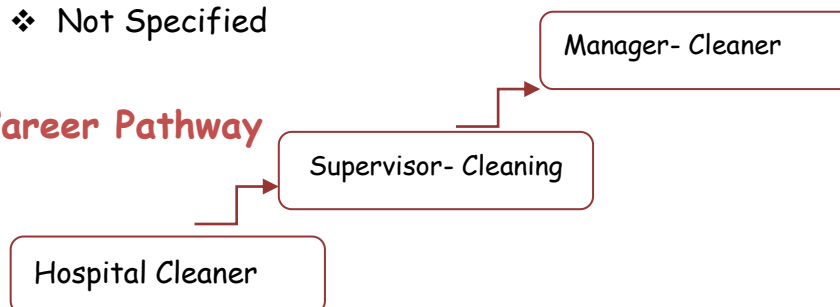

24. House Keeper

■ Level of Position

- ❖ Middle Level

■ Duties and Responsibilities

- ❖ Clean patient rooms, nursing units, surgical areas, administrative offices, laboratory areas, waiting areas and public restrooms, as well as launder all hospital linen
- ❖ Using various cleaning chemicals and disinfectants, housekeepers wipe equipment, clean furniture, polish floors and vacuum carpets
- ❖ Prepare beds, empty trash and restock medical supplies

■ Salary Scale (Rs.)

- ❖ Maximum- Rs.30000/=
- ❖ Minimum - Rs.20000/=

■ Working Hours

- ❖ 9 Hours

■ Age Limit (Years)

- ❖ Upper Limit -55
- ❖ Lower Limit - 18

■ Gender Preference

- ❖ Both Gender

■ Required Educational Qualifications

❖ GCE O/L

■ Diploma & Certificate Qualifications

❖ Not Specified

■ Preferred Institute

❖ Not Specified

■ Language Skills

Language	Expected Level
Sinhala	High
English	Moderate
Tamil	Fair

■ Soft Skills

Communication	Hard Work
Team Work	Multitasking Skill

■ Required Experience

❖ Not Specified

■ Career Pathway

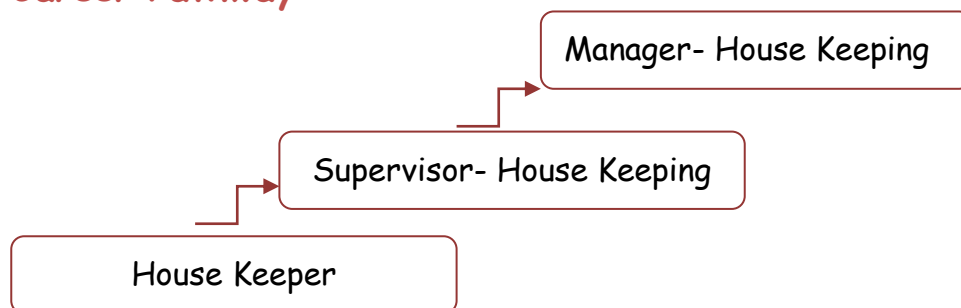

25. Lab Assistant

■ Level of Position

- ❖ Entry Level

■ Duties and Responsibilities

- ❖ To clean and sterilize fibrotic bronchoscope
- ❖ Cleaning and maintenance of lung function test machine
- ❖ To assist the technician in various procedures
- ❖ Cleaning and sterilization of mark and tubing
- ❖ To assist in performance of bronchoscope and other diagnostic procedures in the respiratory laboratory

■ Salary Scale (Rs.)

- ❖ Maximum- Rs.25000/=
- ❖ Minimum - Rs.20000/=

■ Working Hours

- ❖ 8 Hours

■ Age Limit (Years)

- ❖ Upper Limit -55
- ❖ Lower Limit - 18

■ Gender Preference

- ❖ Both Gender

■ Required Educational Qualifications

❖ GCE O/L

■ Diploma & Certificate Qualifications

❖ Not Specified

■ Preferred Institute

❖ Not Specified

■ Language Skills

Language	Expected Level
Sinhala	High
English	Moderate
Tamil	Fair

■ Soft Skills

Communication	Hard Work
Team Work	Multitasking Skill

■ Required Experience

❖ Not Specified

■ Career Pathway

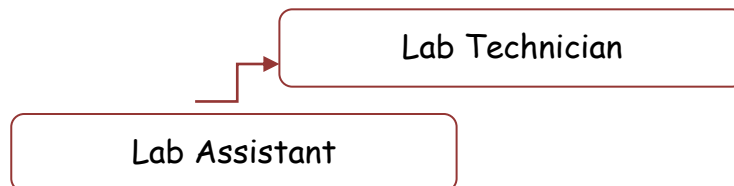

26. Blood Bank Technician

■ Level of Position

- ❖ Middle Level

■ Duties and Responsibilities

- ❖ To receive blood samples for grouping and cross matching along with requisition forms wards/PT/labour room and others
- ❖ To perform emergency duty on rotational basis
- ❖ To perform grouping of all donors (Voluntary), bleeding of donors, labeling, documenting, storing and issuing blood
- ❖ Grouping and cross matching of all blood samples for routine and emergency demand from ward, operation theatre etc. and issuing matched blood as and when required
- ❖ To supervise laboratory attendant in performing his duties

■ Salary Scale (Rs.)

- ❖ Maximum- Rs.50000/=
- ❖ Minimum - Rs.40000/=

■ Working Hours

- ❖ 08 hours

■ Age Limit (Years)

- ❖ Upper Limit -55
- ❖ Lower Limit - 18

■ Gender Preference

- ❖ Both Gender

■ Required Educational Qualifications

- ❖ GCE O/L
- ❖ GCE A/L-Biology
- ❖ Bsc Degree in Microbiology

■ Diploma & Certificate Qualifications

Diploma in related field

■ Preferred Institute

- ❖ Any Recognized Institute in Sri Lanka

■ Language Skills

Language	Expected Level
Sinhala	High
English	High
Tamil	Fair

■ Soft Skills

Communication	Manual dexterity
Problem Solving	Situational awareness
Efficiency	Physical endurance
Attention to detail	Computer competency

■ Required Experience

- ❖ Two Year Experience in related field

■ Career Pathway

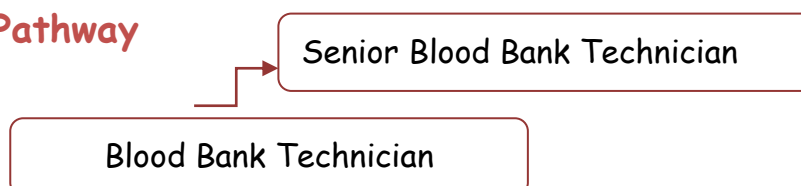

27. Blood Bank Assistant

■ Level of Position

- ❖ Entry Level

■ Duties and Responsibilities

- ❖ To assist laboratory technician in his work
- ❖ To maintain cleanliness of table, washing of glassware in the laboratory area
- ❖ To obtain in-service training in Medical Laboratory Technician programme if facility available

■ Salary Scale (Rs.)

- ❖ Maximum- Rs.25000/=
- ❖ Minimum - Rs.20000/=

■ Working Hours

- ❖ 8 Hours

■ Age Limit (Years)

- ❖ Upper Limit -55
- ❖ Lower Limit - 18

■ Gender Preference

- ❖ Both Gender

■ Required Educational Qualifications

- ❖ GCE O/L & GCE A/L

■ Diploma & Certificate Qualifications

❖ Not Specified

■ Preferred Institute

❖ Not Specified

■ Language Skills

Language	Expected Level
Sinhala	High
English	Moderate
Tamil	Fair

■ Soft Skills

Communication	Hard Work
Team Work	Multitasking Skill

■ Required Experience

❖ Not Specified

■ Career Pathway

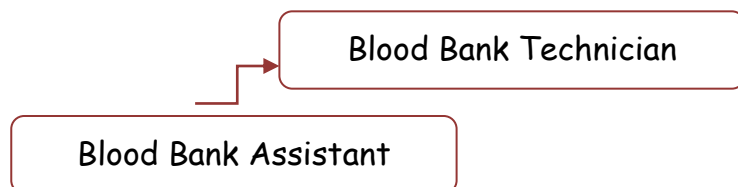

28. Assistant-OT/CCSD

■ Level of Position

- ❖ Entry Level

■ Duties and Responsibilities

- ❖ Packing of syringes, instruments and special trays.
- ❖ Washing and cleaning of gloves, instruments, needles and syringes etc.
- ❖ Maintaining the cleanliness of the deptt. And dusting of issuing area, sterilization area.
- ❖ Messenger service to the wards and department.
- ❖ Supply of cylinders from gas room to wards and department.
- ❖ Report shortages

■ Salary Scale (Rs.)

- ❖ Maximum- Rs.25000/=
- ❖ Minimum - Rs.20000/=

■ Working Hours

- ❖ 8 Hours

■ Age Limit (Years)

- ❖ Upper Limit -55
- ❖ Lower Limit - 18

■ Gender Preference

- ❖ Both Gender

■ Required Educational Qualifications

❖ GCE O/L & GCE A/L

■ Diploma & Certificate Qualifications

❖ Not Specified

■ Preferred Institute

❖ Not Specified

■ Language Skills

Language	Expected Level
Sinhala	High
English	Moderate
Tamil	Fair

■ Soft Skills

Communication	Hard Work
Team Work	Multitasking Skill

■ Required Experience

❖ Not Specified

■ Career Pathway

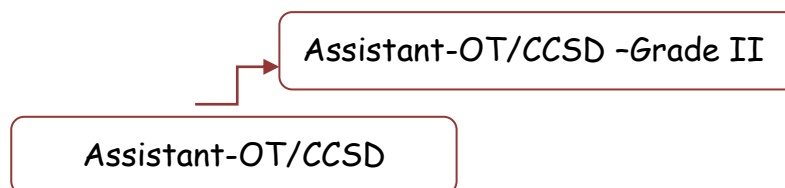

29. Lab Technician (Microbiology)

■ Level of Position

- ❖ Middle Level

■ Duties and Responsibilities

- ❖ To collect specimen and prepare smear for examination
- ❖ Centrifugation and preparation of urine deposits for smear examination and culture and sensitivity to pathogenic organism
- ❖ Taking weight of chemicals for preparing standard solution and preparation of stock media for bacteriological work
- ❖ To autoclave used blood culture bottles and dishes
- ❖ Sterilizing and maintaining glassware by autoclaving.
- ❖ To perform serological tests for various isolated organisms
- ❖ Bacteriological tests to prevent hospital acquired infection
- ❖ To check efficiency of autoclaving of instruments, linen etc. in CSSD
- ❖ To take universal precautions while handling blood and body fluids and to follow guidelines on Hospital Waste management for safe disposal of samples left

■ Salary Scale (Rs.)

- ❖ Maximum- Rs.50000/=
- ❖ Minimum - Rs.45000/=

■ Working Hours

- ❖ 8 Hours

■ Age Limit (Years)

- ❖ Upper Limit -55
- ❖ Lower Limit - 18

■ Gender Preference

- ❖ Both Gender

■ Required Educational Qualifications

- ❖ GCE O/L & GCE A/L-Biology
- ❖ Bsc in Microbiology

■ Diploma & Certificate Qualifications

- ❖ Not Specified

■ Preferred Institute

- ❖ Not Specified

■ Language Skills

Language	Expected Level
Sinhala	High
English	Moderate
Tamil	Fair

■ Soft Skills

Communication	Time Management
Team Work	Self Confidence

■ Required Experience

- ❖ Not Specified

■ Career Pathway

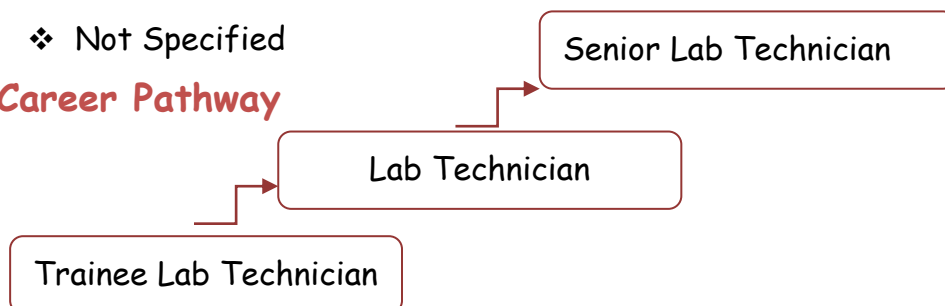

Non Health Related Jobs Represented in Health Sector

30. Accountant

■ Level of Position

- ❖ High Level

■ Duties and Responsibilities

- ❖ Analyze business operations, trends, costs, revenues, financial commitments, and obligations, to project future revenues and expenses or to provide advice
- ❖ Develop, maintain, and analyze budgets, preparing periodic reports that compare budgeted costs to actual costs
- ❖ Prepare forms and manuals for accounting and bookkeeping personnel, and direct their work activities

■ Salary Scale (Rs.)

- ❖ Maximum- Rs.45,000/=
- ❖ Minimum - Rs.35,000/=

■ Working Hours

- ❖ 08 hours

■ Age Limit (Years)

- ❖ Upper Limit -55
- ❖ Lower Limit - 18

■ Gender Preference

- ❖ Both Gender

■ Required Educational Qualifications

- ❖ GCE O/L
- ❖ GCE A/L- Commerce
- ❖ Degree

■ Diploma & Certificate Qualifications

- ❖ AAT/ICASL

■ Preferred Institute

- ❖ Any recognized institute in Sri Lanka

■ Language Skills

Language	Expected Level
Sinhala	High
English	High
Tamil	Fair

■ Soft Skills

Communication	Time Management
Team Work	Dynamic

■ Required Experience

- ❖ Five years experience in Accounts field

■ Career Pathway

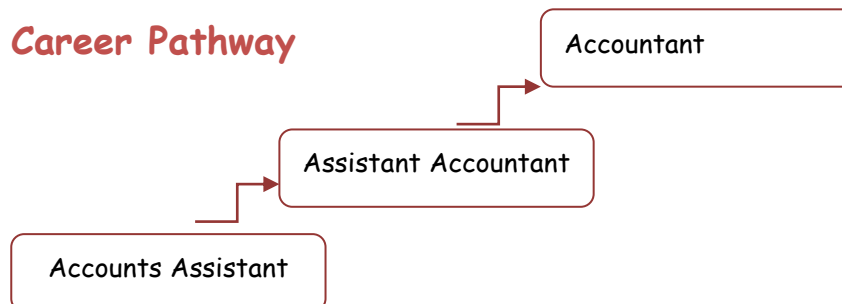

31. Accounts Assistant

■ Level of Position

- ❖ Middle Level

■ Duties and Responsibilities

- ❖ Preparing petty cash book
- ❖ Ready to cheques for suppliers

■ Salary Scale (Rs.)

- ❖ Maximum- Rs.25,000/=
- ❖ Minimum - Rs.20,000/=

■ Working Hours

- ❖ 08 hours

■ Age Limit (Years)

- ❖ Upper Limit -55
- ❖ Lower Limit - 18

■ Gender Preference

- ❖ Both Gender

■ Required Educational Qualifications

- ❖ GCE O/L
- ❖ GCE A/L- Commerce

■ Diploma & Certificate Qualifications

- ❖ AAT

■ Preferred Institute

- ❖ Any recognized institute in Sri Lanka

■ Language Skills

Language	Expected Level
Sinhala	High
English	Moderate
Tamil	Fair

■ Soft Skills

Communication	Time Management
Team Work	IT Skill

■ Required Experience

- ❖ Not Specified

■ Career Pathway

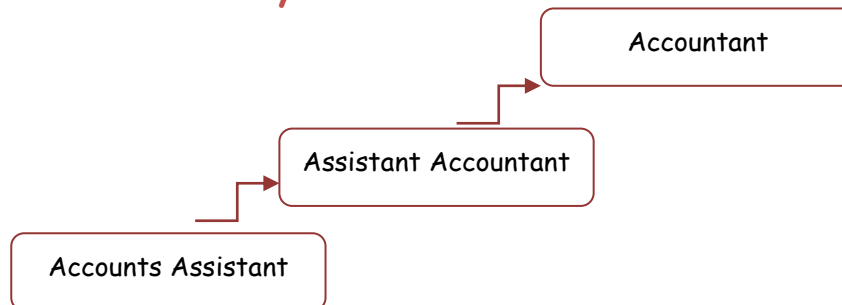

32. Audit Assistant

■ Level of Position

- ❖ Middle Level

■ Duties and Responsibilities

- ❖ Handling Audit function of organization

■ Salary Scale (Rs.)

- ❖ Maximum- Rs.25,000/=
- ❖ Minimum - Rs.20,000/=

■ Working Hours

- ❖ 08 hours

■ Age Limit (Years)

- ❖ Upper Limit -55
- ❖ Lower Limit - 18

■ Gender Preference

- ❖ Both Gender

■ Required Educational Qualifications

- ❖ GCE O/L
- ❖ GCE A/L-Commerce
- ❖ Degree

■ Diploma & Certificate Qualifications

- ❖ AAT/ICASL

■ Preferred Institute

- ❖ Any recognized institute in Sri Lanka

■ Language Skills

Language	Expected Level
Sinhala	High
English	Moderate
Tamil	Fair

■ Soft Skills

Communication	Time Management
Team Work	IT Skill

■ Required Experience

- ❖ Six months training in Audit Field

■ Career Pathway

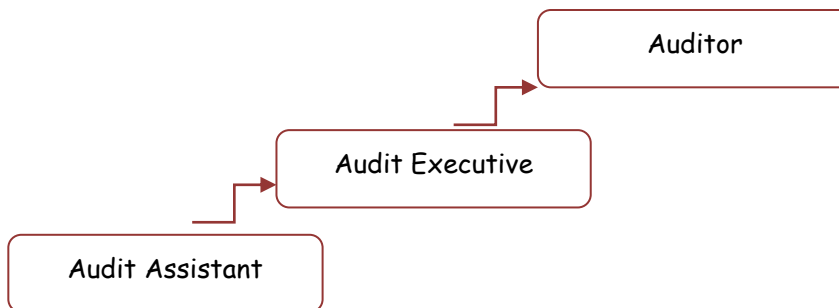

33. Billing Assistant

■ Level of Position

- ❖ Entry Level

■ Duties and Responsibilities

- ❖ Create Patient Bill
- ❖ Maintain Billing

■ Salary Scale (Rs.)

- ❖ Maximum- Rs.25,000/=
- ❖ Minimum - Rs.20,000/=

■ Working Hours

- ❖ 08 hours

■ Age Limit (Years)

- ❖ Upper Limit -55
- ❖ Lower Limit - 18

■ Gender Preference

- ❖ Both Gender

■ Required Educational Qualifications

- ❖ GCE O/L
- ❖ GCE A/L-Commerce

■ Diploma & Certificate Qualifications

- ❖ Certificate in Computer

■ Preferred Institute

- ❖ Any recognized institute in Sri Lanka

■ Language Skills

Language	Expected Level
Sinhala	High
English	Moderate
Tamil	Fair

■ Soft Skills

Communication	Time Management
Team Work	IT Skill

■ Required Experience

- ❖ Two years experience in Accounts
- ❖ Six months experience in Billing

■ Career Pathway

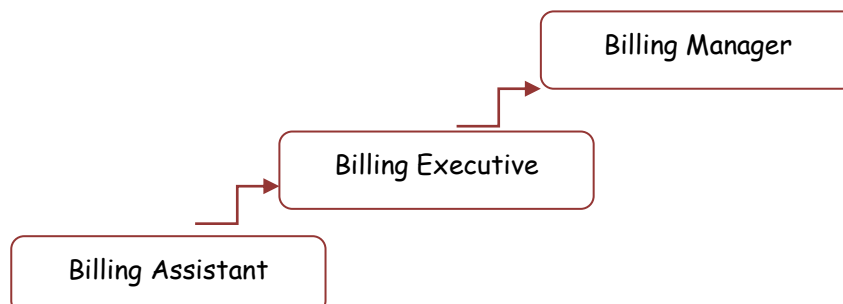

34. Call Center Officer

■ Level of Position

- ❖ Middle Level

■ Duties and Responsibilities

- ❖ Answer telephone promptly and in a polite and professional manner
- ❖ Handling Customer Complain
- ❖ Schedule appointment correctly -review appointment date, time, location, and provider name with caller
- ❖ Inform caller of items to bring to appointment
- ❖ Remind caller to arrive 15 to 30 minutes before scheduled appointment to complete paperwork
- ❖ Remind caller of cancellation/no -show policy

■ Salary Scale (Rs.)

- ❖ Maximum- Rs.20,000/=
- ❖ Minimum - Rs.15,000/=

■ Working Hours

- ❖ 08 hours

■ Age Limit (Years)

- ❖ Upper Limit -55
- ❖ Lower Limit - 18

■ Gender Preference

- ❖ Female Preferred

■ Required Educational Qualifications

- ❖ GCE O/L
- ❖ GCE A/L- Commerce

■ Diploma & Certificate Qualifications

- ❖ Certificate in Computer

■ Preferred Institute

- ❖ Any recognized institute in Sri Lanka

■ Language Skills

Language	Expected Level
Sinhala	High
English	Moderate
Tamil	Fair

■ Soft Skills

Communication	Language Skill
Team Work	IT Skill

■ Required Experience

- ❖ Not Specified

■ Career Pathway

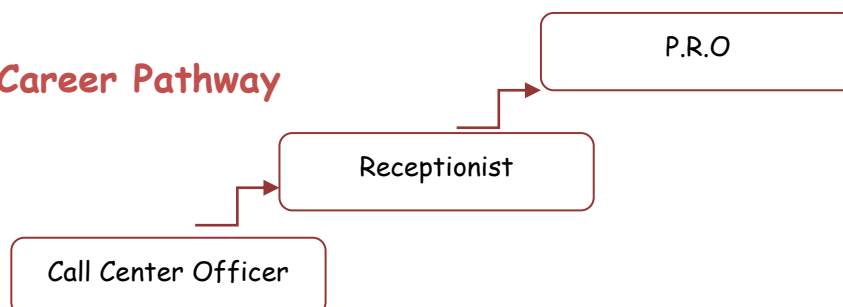

35. Cashier

■ Level of Position

- ❖ Entry Level

■ Duties and Responsibilities

- ❖ Handling cash payments

■ Salary Scale (Rs.)

- ❖ Maximum- Rs.25,000/=
- ❖ Minimum - Rs.20,000/=

■ Working Hours

- ❖ 08 hours

■ Age Limit (Years)

- ❖ Upper Limit -55
- ❖ Lower Limit - 18

■ Gender Preference

- ❖ Both Gender

■ Required Educational Qualifications

- ❖ GCE O/L
- ❖ GCE A/L- Commerce

■ Diploma & Certificate Qualifications

- ❖ AAT

■ Preferred Institute

- ❖ Any recognized institute in Sri Lanka

■ Language Skills

Language	Expected Level
Sinhala	High
English	Moderate
Tamil	Fair

■ Soft Skills

Communication	Hard Work
Team Work	IT Skill

■ Required Experience

- ❖ One Year experience in Finance

■ Career Pathway

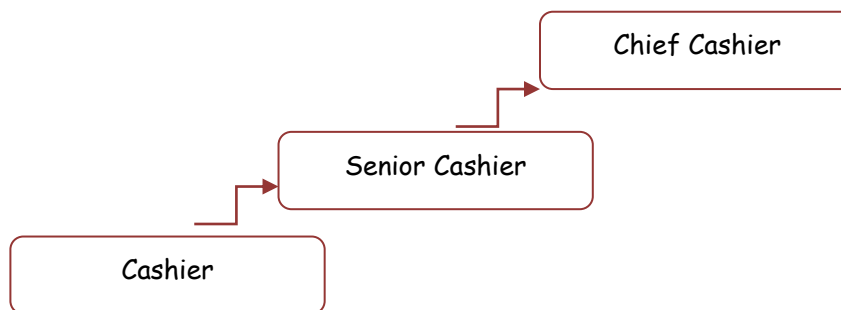

36. Channel Aid

■ Level of Position

- ❖ Middle Level

■ Duties and Responsibilities

- ❖ Assist for the Doctors

■ Salary Scale (Rs.)

- ❖ Maximum- Rs.25,000/=
- ❖ Minimum - Rs.20,000/=

■ Working Hours

- ❖ 08 hours

■ Age Limit (Years)

- ❖ Upper Limit -55
- ❖ Lower Limit - 18

■ Gender Preference

- ❖ Both Gender

■ Required Educational Qualifications

- ❖ GCE O/L & GCE A/L

■ Diploma & Certificate Qualifications

- ❖ Not mentioned

■ Preferred Institute

❖ Not Mentioned

■ Language Skills

Language	Expected Level
Sinhala	High
English	Moderate
Tamil	Fair

■ Soft Skills

Communication	Kindness
Team Work	IT Skill

■ Required Experience

❖ One Year Experience in Nursing

■ Career Pathway

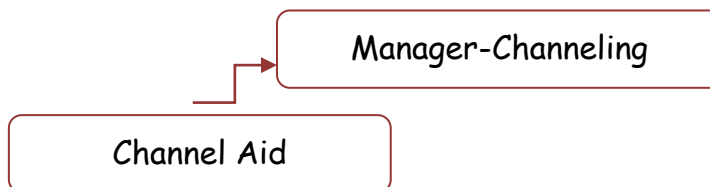

37. Cook

■ Level of Position

- ❖ Middle Level

■ Duties and Responsibilities

- ❖ Measure and assemble ingredients for menu items
- ❖ Collaborate with the Executive Chef and Cooks to prepare meals during our dining hours
- ❖ Maintain accurate food inventories
- ❖ Properly store food items at appropriate temperatures
- ❖ Ensure that the food prep area and kitchen are cleaned and sanitized at the end of your shift

■ Salary Scale (Rs.)

- ❖ Maximum- Rs.30,000/=
- ❖ Minimum - Rs.25,000/=

■ Working Hours

- ❖ 08 hours

■ Age Limit (Years)

- ❖ Upper Limit -55
- ❖ Lower Limit - 18

■ Gender Preference

- ❖ Both Gender

■ Required Educational Qualifications

- ❖ GCE O/L & GCE A/L

■ Diploma & Certificate Qualifications

- ❖ Certificate in Cookery

■ Preferred Institute

- ❖ Any recognized institute in Sri Lanka

■ Language Skills

Language	Expected Level
Sinhala	High
English	Moderate
Tamil	Fair

■ Soft Skills

Communication	Being Personality
Team Work	Positive Attitude

■ Required Experience

- ❖ Two Years in Cookery Field

■ Career Pathway

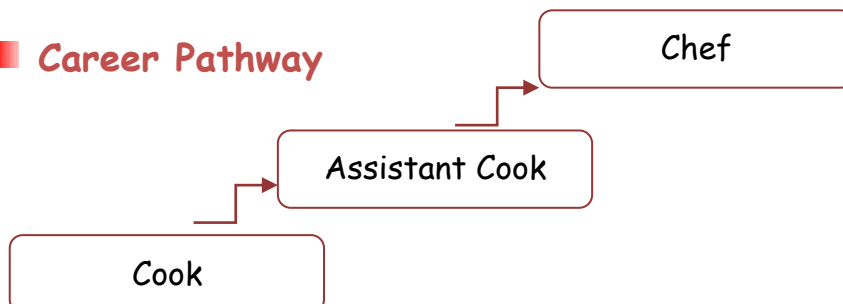

38. Courier

■ Level of Position

- ❖ Entry Level

■ Duties and Responsibilities

- ❖ Receive messages or materials to be delivered, and information on recipients, such as names, addresses, telephone numbers, and delivery instructions, communicated via telephone
- ❖ Call by telephone in order to deliver verbal messages

■ Salary Scale (Rs.)

- ❖ Maximum- Rs.25,000/=
- ❖ Minimum - Rs.20,000/=

■ Working Hours

- ❖ 08 hours

■ Age Limit (Years)

- ❖ Upper Limit -55
- ❖ Lower Limit - 18

■ Gender Preference

- ❖ Male Preferred

■ Required Educational Qualifications

- ❖ GCE O/L & GCE A/L

■ Diploma & Certificate Qualifications

- ❖ Not Mentioned

■ Preferred Institute

- ❖ Any recognized institute in Sri Lanka

■ Language Skills

Language	Expected Level
Sinhala	High
English	Moderate
Tamil	Fair

■ Soft Skills

Communication	Work Hard
Team Work	Positive Attitude

■ Required Experience

- ❖ Not Specified

■ Career Pathway

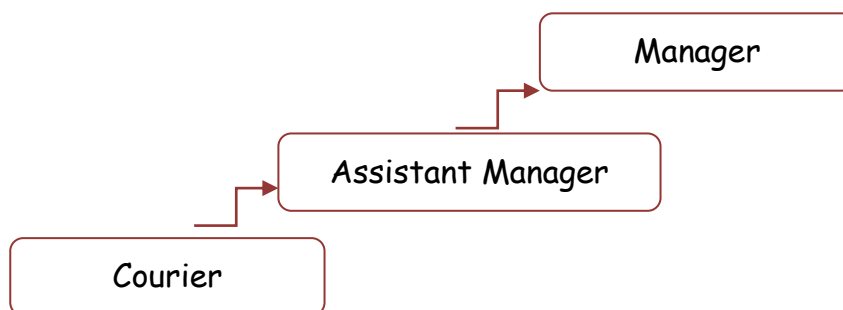

39. Data Entry Operator

■ Level of Position

- ❖ Entry Level

■ Duties and Responsibilities

- ❖ Enter the data correctly

■ Salary Scale (Rs.)

- ❖ Maximum- Rs.20,000/=
- ❖ Minimum - Rs.20,000/=

■ Working Hours

- ❖ 08 hours

■ Age Limit (Years)

- ❖ Upper Limit -55
- ❖ Lower Limit - 18

■ Gender Preference

- ❖ Both Gender

■ Required Educational Qualifications

- ❖ GCE O/L & GCE A/L

■ Diploma & Certificate Qualifications

- ❖ Diploma in Computer

■ Preferred Institute

- ❖ Any recognized institute in Sri Lanka

■ Language Skills

Language	Expected Level
Sinhala	High
English	Moderate
Tamil	Fair

■ Soft Skills

Communication	Work Hard
Team Work	Positive Attitude

■ Required Experience

- ❖ One Year experience in Data Entry

■ Career Pathway

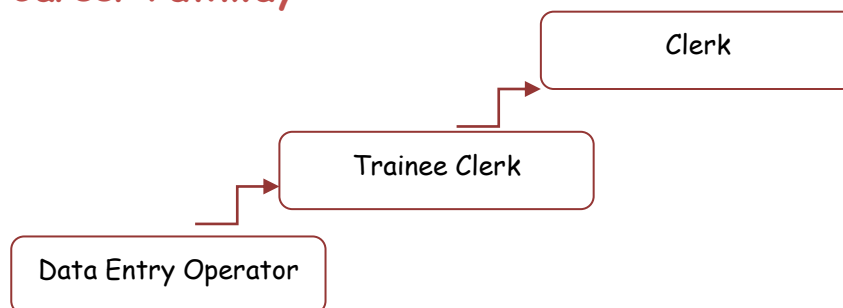

40. House Keeping Assistant

■ Level of Position

- ❖ Entry Level

■ Duties and Responsibilities

- ❖ Ensuring all facilities including living accommodations are thoroughly cleaned on a daily basis
- ❖ Assist with pick up and delivery of all soiled linens from residential areas to cleaners
- ❖ Assist the medical team, the kitchen, the facilities team, and cabin and program staff and as needed
- ❖ Maintain inventories of linens, cleaning equipment, and all other supplies

■ Salary Scale (Rs.)

- ❖ Maximum- Rs.20,000/=
- ❖ Minimum - Rs.20,000/=

■ Working Hours

- ❖ 08 hours

■ Age Limit (Years)

- ❖ Upper Limit -55
- ❖ Lower Limit - 18

■ Gender Preference

- ❖ Both Gender

■ Required Educational Qualifications

❖ GCE O/L

■ Diploma & Certificate Qualifications

❖ Not Specified

■ Preferred Institute

❖ Not Specified

■ Language Skills

Language	Expected Level
Sinhala	High
English	Moderate
Tamil	Fair

■ Soft Skills

Communication	Work Hard
Team Work	Positive Attitude

■ Required Experience

❖ Not Specified

■ Career Pathway

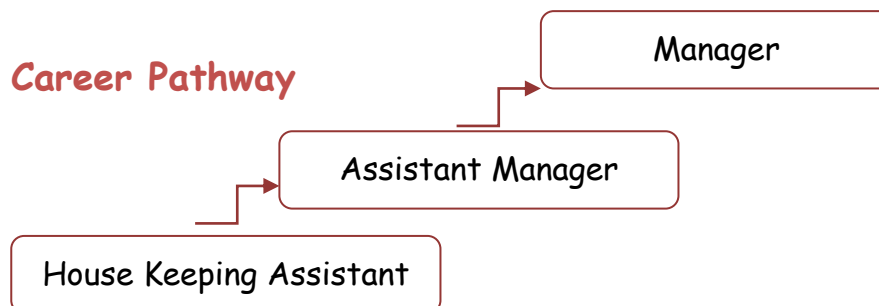

41. Human Resource Assistant

■ Level of Position

- ❖ Middle Level

■ Duties and Responsibilities

- ❖ Preparing appointment letters
- ❖ Preparing doctors payments,
- ❖ Preparing employee ID
- ❖ Preparing documents for salary
- ❖ Recruitment and Selection
- ❖ Grievance Handling
- ❖ Attendance and leave management, Disciplinary action

■ Salary Scale (Rs.)

- ❖ Maximum- Rs.30,000/=
- ❖ Minimum - Rs.25,000/=

■ Working Hours

- ❖ 08 hours

■ Age Limit (Years)

- ❖ Upper Limit -55
- ❖ Lower Limit - 18

■ Gender Preference

- ❖ Both Gender

■ Required Educational Qualifications

- ❖ GCE O/L & GCE A/L
- ❖ Degree

■ Diploma & Certificate Qualifications

- ❖ Diploma in Human Resource Management

■ Preferred Institute

- ❖ Institute of Personnel Management
- ❖ Any Recognized Institute in Sri Lanka

■ Language Skills

Language	Expected Level
Sinhala	High
English	Moderate
Tamil	Fair

■ Soft Skills

Communication	English Language Ability
Team Work	Positive Attitude

■ Required Experience

- ❖ Six Months Experience in HRM field

■ Career Pathway

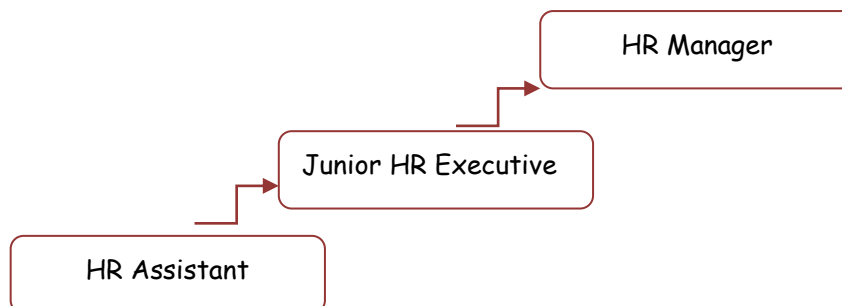

42. Kitchen Helper

■ Level of Position

- ❖ Entry Level

■ Duties and Responsibilities

- ❖ Help to chef
- ❖ Clean kitchen department

■ Salary Scale (Rs.)

- ❖ Maximum- Rs.22,000/=
- ❖ Minimum - Rs.20,000/=

■ Working Hours

- ❖ 08 hours

■ Age Limit (Years)

- ❖ Upper Limit -55
- ❖ Lower Limit - 18

■ Gender Preference

- ❖ Both Gender

■ Required Educational Qualifications

- ❖ GCE O/L & GCE A/L

■ Diploma & Certificate Qualifications

- ❖ Certificate in Cookery

■ Preferred Institute

- ❖ Any recognized institute in Sri Lanka

■ Language Skills

Language	Expected Level
Sinhala	High
English	Moderate
Tamil	Fair

■ Soft Skills

Communication	Cleanliness
Team Work	Positive Attitude

■ Required Experience

- ❖ Not Specified

■ Career Pathway

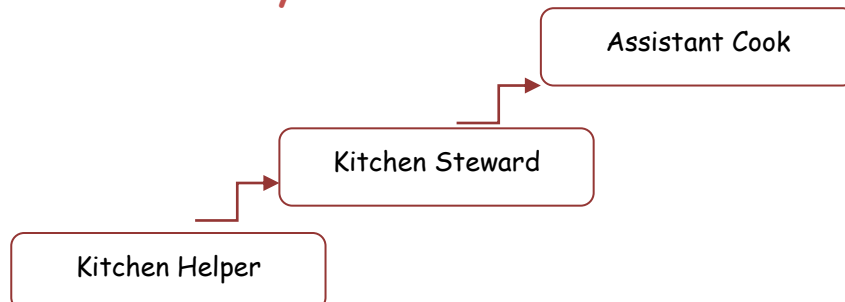

43. Laundry Assistant

■ Level of Position

- ❖ Middle Level

■ Duties and Responsibilities

- ❖ Cleaning cloths & Bed sheets
- ❖ Washing Bed sheets
- ❖ Washing all cloths

■ Salary Scale (Rs.)

- ❖ Maximum- Rs.25,000/=
- ❖ Minimum - Rs.20,000/=

■ Working Hours

- ❖ 08 hours

■ Age Limit (Years)

- ❖ Upper Limit -55
- ❖ Lower Limit - 18

■ Gender Preference

- ❖ Both Gender

■ Required Educational Qualifications

- ❖ GCE O/L & GCE A/L

■ Diploma & Certificate Qualifications

- ❖ Not Specified

■ Preferred Institute

- ❖ Any recognized institute in Sri Lanka

■ Language Skills

Language	Expected Level
Sinhala	High
English	Moderate
Tamil	Fair

■ Soft Skills

Communication	Cleanliness
Hard Work	Honesty

■ Required Experience

- ❖ Two Years in Laundry Service field

■ Career Pathway

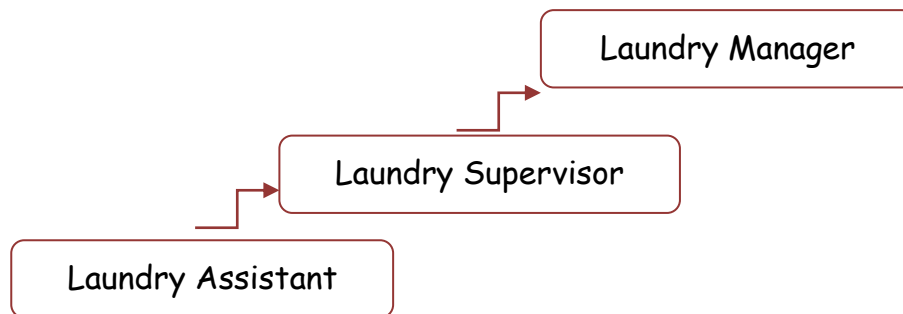

44. Laundry Supervisor

■ Level of Position

- ❖ Middle Level

■ Duties and Responsibilities

- ❖ Staff Maintain
- ❖ Supervise the activities in Laundry Section

■ Salary Scale (Rs.)

- ❖ Maximum- Rs.45,000/=
- ❖ Minimum - Rs.40,000/=

■ Working Hours

- ❖ 08 hours

■ Age Limit (Years)

- ❖ Upper Limit -55
- ❖ Lower Limit - 18

■ Gender Preference

- ❖ Both Gender

■ Required Educational Qualifications

- ❖ GCE O/L & GCE A/L

■ Diploma & Certificate Qualifications

- ❖ Not Specified

■ Preferred Institute

- ❖ Not Specified

■ Language Skills

Language	Expected Level
Sinhala	High
English	Moderate
Tamil	Fair

■ Soft Skills

- ❖ Technical Skill
- ❖ Communication

■ Required Experience

- ❖ Not Specified

■ Career Pathway

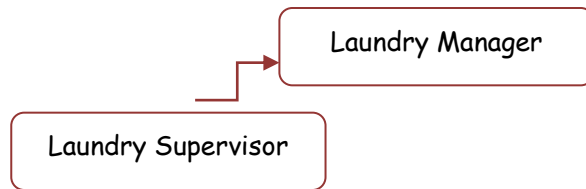

45. Public Relation Officer

■ Level of Position

- ❖ Middle Level

■ Duties and Responsibilities

- ❖ Customer Handling

■ Salary Scale (Rs.)

- ❖ Maximum- Rs.25,000/=
- ❖ Minimum - Rs.20,000/=

■ Working Hours

- ❖ 08 hours

■ Age Limit (Years)

- ❖ Upper Limit -55
- ❖ Lower Limit - 18

■ Gender Preference

- ❖ Both Gender

■ Required Educational Qualifications

- ❖ GCE O/L
- ❖ GCE A/L-Commerce/Arts

■ Diploma & Certificate Qualifications

- ❖ Not Specified

■ Preferred Institute

- ❖ Not Specified

■ Language Skills

Language	Expected Level
Sinhala	High
English	Moderate
Tamil	Fair

■ Soft Skills

- ❖ Communication
- ❖ Interpersonal

■ Required Experience

- ❖ Not Specified

■ Career Pathway

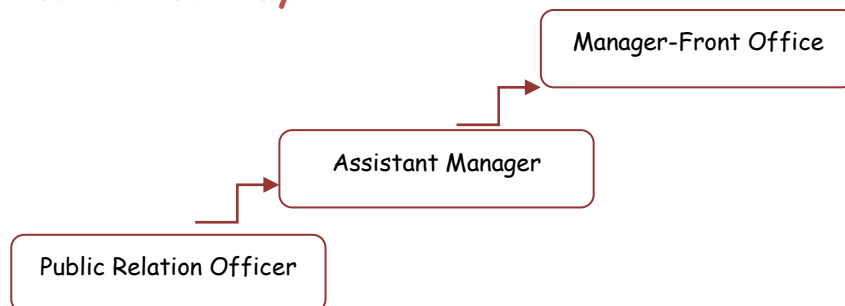

46. Stock Handling Assistant

■ Level of Position

- ❖ Middle Level

■ Duties and Responsibilities

- ❖ Check all items in the Stock
- ❖ Good Received Notice
- ❖ Posting

■ Salary Scale (Rs.)

- ❖ Maximum- Rs.20,000/=
- ❖ Minimum - Rs.18,000/=

■ Working Hours

- ❖ 08 hours

■ Age Limit (Years)

- ❖ Upper Limit -55
- ❖ Lower Limit - 18

■ Gender Preference

- ❖ Both Gender

■ Required Educational Qualifications

- ❖ GCE O/L
- ❖ GCE A/L- Commerce/IT

■ Diploma & Certificate Qualifications

- ❖ Not Specified

■ Preferred Institute

- ❖ Not Specified

■ Language Skills

Language	Expected Level
Sinhala	High
English	Moderate
Tamil	Fair

■ Soft Skills

- ❖ Communication
- ❖ Public Relation
- ❖ Efficiency

■ Required Experience

- ❖ Not Specified

■ Career Pathway

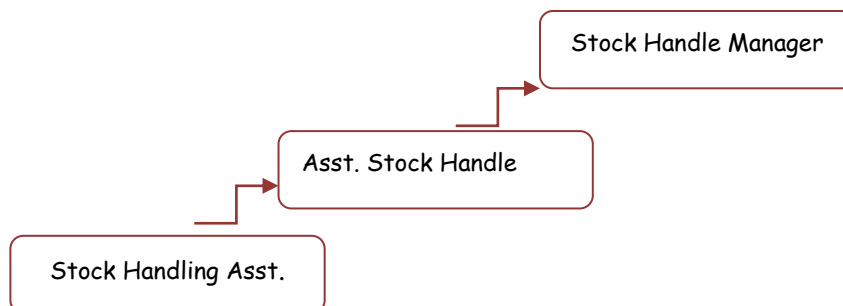

47. Store Keeper

■ Level of Position

- ❖ Middle Level

■ Duties and Responsibilities

- ❖ Issue the stationary items
- ❖ GRN Procedure
- ❖ Maintaining the kitchen items
- ❖ Maintaining all items and uniforms

■ Salary Scale (Rs.)

- ❖ Maximum- Rs.25,000/=
- ❖ Minimum - Rs.20,000/=

■ Working Hours

- ❖ 08 hours

■ Age Limit (Years)

- ❖ Upper Limit -55
- ❖ Lower Limit - 18

■ Gender Preference

- ❖ Both Gender

■ Required Educational Qualifications

- ❖ GCE O/L
- ❖ GCE A/L- Commerce/ Arts

■ Diploma & Certificate Qualifications

- ❖ Not Specified

■ Preferred Institute

- ❖ Not Specified

■ Language Skills

Language	Expected Level
Sinhala	High
English	Moderate
Tamil	Fair

■ Soft Skills

- ❖ Personality
- ❖ Team Work

■ Required Experience

- ❖ Not Specified

■ Career Pathway

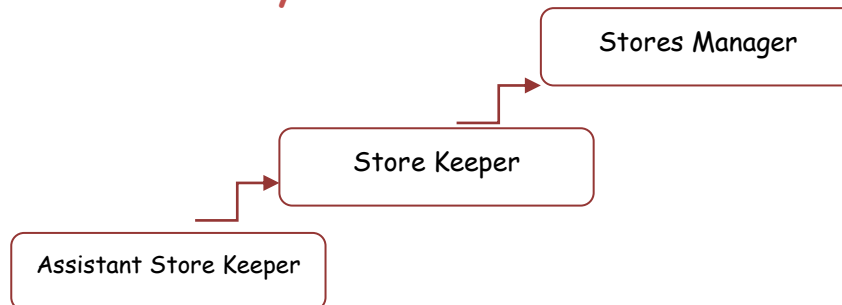

48. Stores Executive

■ Level of Position

- ❖ Middle Level

■ Duties and Responsibilities

- ❖ Bin card Balance
- ❖ Issued material items to the Department

■ Salary Scale (Rs.)

- ❖ Maximum- Rs.30,000/=
- ❖ Minimum - Rs.25,000/=

■ Working Hours

- ❖ 08 hours

■ Age Limit (Years)

- ❖ Upper Limit -55
- ❖ Lower Limit - 18

■ Gender Preference

- ❖ Both Gender

■ Required Educational Qualifications

- ❖ GCE O/L
- ❖ GCE A/L- Commerce
- ❖ Degree

■ Diploma & Certificate Qualifications

- ❖ Not Specified

■ Preferred Institute

- ❖ Not Specified

■ Language Skills

Language	Expected Level
Sinhala	High
English	Moderate
Tamil	Fair

■ Soft Skills

- ❖ Communication
- ❖ IT
- ❖ Team Work

■ Required Experience

- ❖ Not Specified

■ Career Pathway

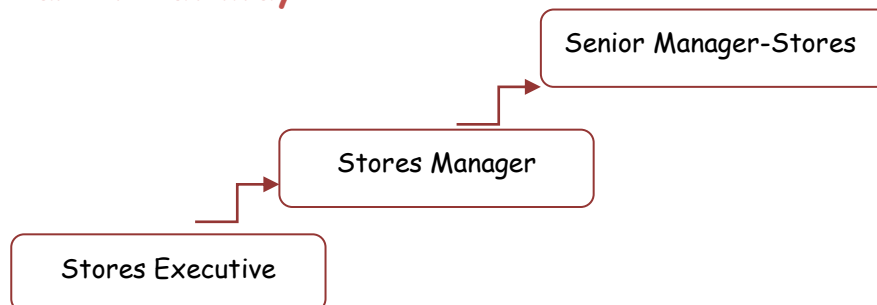

49. Administrative Officer

■ Level of Position

- ❖ Middle Level

■ Duties and Responsibilities

- ❖ Handling Administrative Work

■ Salary Scale (Rs.)

- ❖ Maximum- Rs.20000/=
- ❖ Minimum - Rs.15000/=

■ Working Hours

- ❖ 8 Hours

■ Age Limit (Years)

- ❖ Upper Limit -55
- ❖ Lower Limit - 18

■ Gender Preference

- ❖ Both Gender

■ Required Educational Qualifications

- ❖ GCE O/L
- ❖ GCE A/L

■ Diploma & Certificate Qualifications

- ❖ Computer Application Diploma

■ Preferred Institute

- ❖ Any Recognized Institute in Sri Lanka

■ Language Skills

Language	Expected Level
Sinhala	High
English	Moderate
Tamil	Fair

■ Soft Skills

- ❖ Communication
- ❖ Team Work

■ Required Experience

- ❖ Not Specified

■ Career Pathway

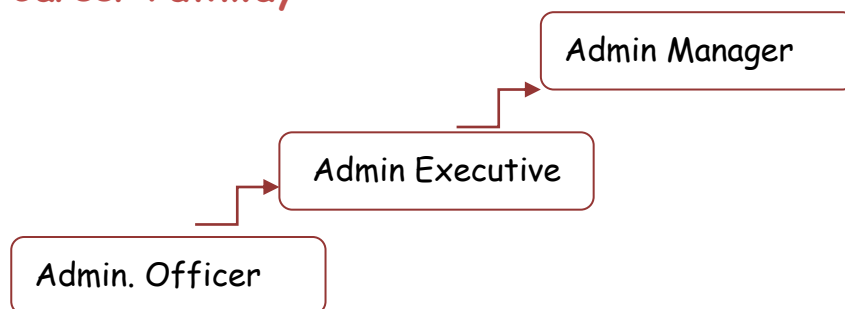

50. Driver

■ Level of Position

- ❖ Entry Level

■ Duties and Responsibilities

- ❖ Vehicle maintain
- ❖ Drive the Vehicle

■ Salary Scale (Rs.)

- ❖ Maximum- Rs.30,000/=
- ❖ Minimum - Rs.20,000/=

■ Working Hours

- ❖ 08 hours

■ Age Limit (Years)

- ❖ Upper Limit -55
- ❖ Lower Limit - 18

■ Gender Preference

- ❖ Male Preferred

■ Required Educational Qualifications

- ❖ GCE O/L & GCE A/L

■ Diploma & Certificate Qualifications

- ❖ Not Specified

■ Preferred Institute

- ❖ Not Specified

■ Language Skills

Language	Expected Level
Sinhala	High
English	Moderate
Tamil	Fair

■ Soft Skills

- ❖ Hard Work
- ❖ Interpersonal

■ Required Experience

- ❖ Two Years in Driving

■ Career Pathway

